

V. *On Hydrofluoric Acid.* By G. GORE, F.R.S.

Received November 14, 1868,—Read January 28, 1869.

A. *Anhydrous Hydrofluoric Acid.*

THE method I have adopted to obtain this compound is the same as that employed by FREMY*, viz. to heat to redness dry double fluoride of hydrogen and potassium in a suitable platinum apparatus.

As the results I have obtained differ somewhat from those described by FREMY, and as the anhydrous acid has been considered to be a *gas* by him and by several other able investigators†, it will be necessary for me to state with a sufficient degree of minuteness the conditions of my experiments.

Pure aqueous hydrofluoric acid, prepared by the method described in this paper (page 196), and free from sulphuric, sulphurous, hydrosulphuric, hydrochloric, and hydrofluosilicic acid, also from sulphur, arsenic (except minute traces), and all fixed substances, was added to carbonate of potassium (free from chlorides, sulphates, and silica) in a large platinum dish, until the liquid on evaporation evolved a distinct acid odour, and the vapour reddened litmus-paper. The clear solution was evaporated to perfect dryness, and the residue gently heated until it fused to a clear thin liquid, free from films upon its surface; it evolved a trace of acid vapour during the process, and did not corrode the platinum vessel. The salt when cooled formed a rather hard, white, non-deliquescent mass; but if the acid was in much excess the fused salt had tough films upon its surface, and formed on cooling a less hard, less white, and more transparent mass.

To obtain the acid from this salt, about 2800 grains weight of fragments of the substance was put into a platinum retort of the annexed form (fig. 1), about 6 inches (=15·3 centimetres) deep and 1½ inch (=3·8 centimetres) diameter, and gently heated to complete fusion to expel any traces of water. The vessel was then fitted air-tight (by means of melted sulphur mixed with lampblack) to a closely fitting platinum tube, about 36 inches (=91·5 centimetres) long, of a LIEBIG'S condenser, A (fig. 3), the condenser being supplied with a freezing-mixture, composed of 1 part of pounded ice

Fig. 1.

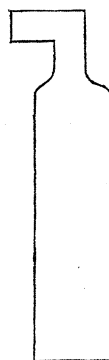
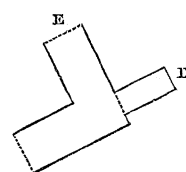

Fig. 2.



* Ann. de Chimie (3), vol. xlvii. p. 5; Comptes Rendus, No. 9, Feb. 27th, 1854.

† *Vide* FREMY, Comptes Rendus, No. 9, Feb. 27th, 1854; LOUYER, Comptes Rendus, vol. xxii. p. 960; also MILLER, Elements of Chemistry, part 2, 4th edition, p. 161.

and $1\frac{1}{2}$ part of crystallized chloride of calcium, through the open tube B. A platinum bottle, C, immersed in a similar freezing-mixture, was employed to receive the distillate. The bottle was provided with a three-necked angle-tube of platinum (see fig. 2), through the narrow opening, D, of which the condensing-tube passed into the bottle, and the angle-tube had a long exit-tube of platinum, F, fixed upon its larger opening, E. The exit-tube had upon its upper end a short angle-tube of platinum, G, turned downwards to prevent attracted moisture running down into the bottle (see fig. 3)*. The tubes all fitted tightly, and the *cold* junctions were made gas-tight by means of a mixture of melted paraffin and lampblack†.

Heat was now gradually applied and the acid rapidly distilled until (in about twenty minutes) the bottom of the retort became red-hot, indicating a completion of the process. The materials bumped considerably towards the end of the process (this may be diminished by applying the heat to the *side* of the retort), and a small quantity of the salt was

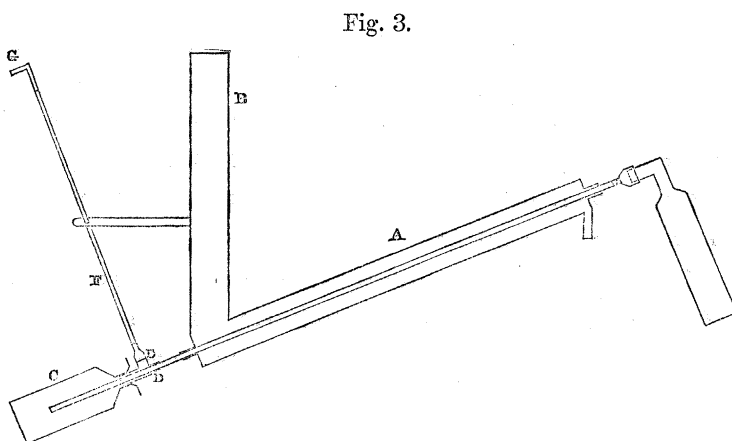

carried mechanically over. The freezing-mixture is indispensable, and careful management of the heat is required. Care must be taken to have all parts of the apparatus quite free from moisture, and also from traces of fluoride of potassium, which is highly deliquescent, and is acted upon with dangerous violence by the acid. The acid was redistilled without exposing it to the air, the retort being immersed in a bath of slightly warm water, kept at a temperature not exceeding 100° FAHR.; under these circumstances any traces of water contained by the acid was retained in the retort by the small quantity of saline matter. 2800 grains of the acid usually carried over mechanically about 5 or 10 grains of saline matter in the first distillation.

The acid thus obtained is a highly dangerous substance, and requires the most extreme care in its manipulation‡: it left no fixed residue on evaporation; it was a perfectly

* All the platinum apparatus used in this investigation was constructed for me with great care by Messrs. MATTHEY and Co., and without such apparatus the experiments could not possibly have been made.

† Paraffin answers admirably for resisting hydrofluoric acid where heat is not applied; it may easily be formed into stoppers, cups, plates, rods, and almost any desired shape; it is, however, liable to become full of cracks when suddenly immersed in a freezing-mixture. Temporary stoppers were conveniently made by melting paraffin in a test-tube, and then breaking the tube.

‡ The highly dangerous nature of the anhydrous acid has received further confirmation in the recent sudden death of Professor NICKLÈS of Nancy, which, according to the 'Moniteur Belge' of April 14th, 1869, was occasioned by accidentally inhaling the vapour of the concentrated acid whilst engaged in making experiments to isolate fluorine.

colourless and transparent liquid at 60° FAHR., very thin and mobile, extremely volatile, densely fuming in the air at ordinary temperatures, and attracted water greedily from the atmosphere. It was perfectly retained in platinum bottles, the bottles having a flanged mouth, a platinum plate coated on its lower side with the paraffin mixture (see page 174) being tightly secured to the flanged mouth by eight clamp screws (see figure 4). The acid must be kept in a cool place, not above a temperature of 60° FAHR., otherwise it is very likely to burst the bottle; and a freezing-mixture should always be at hand whilst experimenting with it.

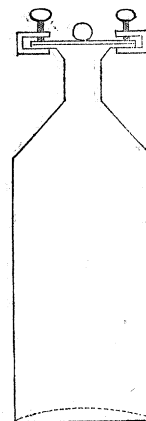

Fig. 4.

According to LOUYET* anhydrous hydrofluoric acid, obtained by distilling oil of vitriol and fluor-spar, and redistilling the condensed product with anhydrous phosphoric acid, is a *gaseous* substance and does not liquefy at -12° C. ($=+10^{\circ}\cdot4$ FAHR.) under ordinary atmospheric pressure; it fumes very strongly in the air, is rapidly condensed by water, has scarcely any action upon glass, and might probably be collected in glass vessels over mercury. According to FREMY† (who states that he assisted at the performance of M. LOUYET's experiments, and did not consider the results satisfactory), the dehydration effected by means of anhydrous phosphoric acid is not complete. He states that anhydrous hydrofluoric acid obtained by the distillation of dry double fluoride of hydrogen and potassium is *gaseous* at the ordinary temperature, but may be condensed at -20° C. by a mixture of ice and salt; it is then a very fluid liquid, volatilizing when removed from the cooling mixture, acting very powerfully upon water, diffusing white fumes in the air with an intensity like that of fluoride of boron, and, contrary to M. LOUYET's assertion, attacks glass rapidly‡.

To ascertain, therefore, whether the liquid I had thus obtained was really anhydrous or not, I made the following analytical experiments:—1st. I took 100 grains of the recently and well-dried double fluoride (which soon attracts a little moisture from the air), and heated it gently with constant motion in a platinum dish until it was all fused; it evolved an acid odour, and lost 0·8 grain in weight. I now again slowly fused it, gradually increasing the heat until at an incipient red heat it was quite solid and evolved no more acid odour, then cooled it under a cover and weighed quickly; its loss was now increased to 25·57 grains, the calculated theoretic loss of anhydrous hydrofluoric acid being 25·59 grains, assuming the salt to be KF, HF.

$$\begin{array}{r} \text{K} = 39\cdot1 \\ \text{F} = 19\cdot0 \\ \text{HF} = 20\cdot0 \\ \hline \text{KF, HF} = 78\cdot1 \end{array}$$

* Comptes Rendus, vol. xxii. p. 960; also GMELIN's Handbook of Chemistry, vol. ii. p. 361.

† Comptes Rendus, No. 9, Feb. 27th, 1854; also 'The Chemist,' June 1854.

‡ FREMY also obtained the anhydrous acid by heating fluoride of lead (contained in a charcoal boat within a platinum tube) in a current of dry hydrogen, and DEVILLE obtained the dry acid by passing hydrochloric-acid gas over highly heated fluor-spar (Comptes Rendus; also Chemist, New Series, vol. iv. p. 330, and vol. ix. p. 556).

BERZELIUS found 25.1 per cent. of volatile matter in this salt, and also obtained 11.6 per cent. of water by heating the salt with six times its weight of protoxide of lead = 1.288 per cent. of hydrogen in it; theory requires 1.280 per cent.* In a second trial 800 grains of the salt, which had been previously fused, was gradually heated to redness; it lost 204.6 grains (= 25.575 per cent.), the theoretic quantity of HF being 204.78 grains. In a third experiment 2063.6 grains of the salt, which had not been sufficiently heated, lost 547 grains (including a little saline matter) in the process of distillation (it should have lost only 528 grains); for the analysis of the acid obtained from it see page 179.

2nd. I took another 100 grains of the same salt, dissolved it in water in a capacious platinum dish, added $1\frac{1}{2}$ ounce of pure and strong hydrochloric acid, and evaporated nearly to dryness, then added more of the acid and slowly heated to perfect dryness, and finally to low redness; the weight of the residue was 95.45 grains, theory requiring 95.47 grains of chloride of potassium.

3rd. I now made several attempts to determine the amount of fluorine in the salt by means of silica. I took 78.2 grains of the perfectly dry salt, reduced it to fine powder, added 50 grains of pure precipitated silica (which was previously found to lose no weight by being boiled in strong sulphuric acid), and mixed them together in a platinum bottle; then added in small portions at a time a quarter of an ounce by measure of strong sulphuric acid, and after awhile applied heat gradually until the sulphuric acid was considerably expelled. The residue was then thoroughly washed in a filter, dried, heated to redness, and weighed; it amounted to 19.3 grains = 30.7 grains dissolved = 38.56 grains of fluorine, theory requiring 38.05 grains. In a second similar experiment 29.8 grains of silica was dissolved; in a third, with 40.7 grains of silica, 29.6 grains was dissolved; in a fourth experiment, with 100 grains of silica and half an ounce of the acid, 30.1 grains was dissolved; and in a fifth experiment, with 50 grains of silica, and a quarter of an ounce of water added before addition of the acid, 31.3 grains was dissolved: this addition of water appeared to facilitate the action by rendering the mixture more fluid, and also by retaining the liberated hydrofluoric-acid gas in solution until it had time to act upon the silica. The average quantity of silica dissolved in these five experiments was 30.30 grains, theory requiring 30.277 grains. The silica being highly hygroscopic was the chief cause of the variation in the numbers obtained; it was (in some of the experiments) cooled and weighed in a stoppered bottle, or in a platinum box (with closely fitting lid) in which it had been heated. In similar experiments, with 100 and 200 grains of purified fine white sand substituted for the precipitated silica, only 6.05 and 8.5 grains respectively were dissolved; these results, compared with those obtained with the precipitated silica, show that unless the silica is very finely divided, much hydrofluoric acid is apt to escape without acting upon it.

From the results obtained with the precipitated silica I conclude (1st) that the whole of the fluorine contained in the salt is evolved as tetrafluoride of silicon, Si F_4 , and not any as hydrofluosilicic acid, notwithstanding the presence of water formed by the reaction,

* Gmelin's Handbook of Chemistry, vol. iii. p. 65.

or even of a limited amount of water added, as in the fifth experiment, and (2nd) that an equivalent, or 78·13 parts, of the dry salt contains two equivalents, or 38 parts, of fluorine; and therefore from these results, combined with the amount of potassium found as chloride in the foregoing determination, I conclude that the salt cannot contain more than a very minute amount, if any, of oxygen or water.

I also checked the foregoing results by neutralizing a known weight of the distilled acid with carbonate of calcium. The first approximate and reliable result was obtained as follows. Into a weighed platinum bottle was poured 33·18 grains of the acid; the stopper was reinserted, and the vessel and contents reweighed. The stopper was now taken out and replaced by a tightly fitting and open vertical tube of platinum about 22 inches (=55·9 centimetres) high, with a stopper at its upper end, the junction of the tube with the bottle being made gas-tight by means of melted paraffin. The bottle was then immersed in ice, and about one-eighth of an ounce of distilled water added drop by drop through the tube. After awhile 102·7 grains of white marble in very fine powder was very gradually added; the mixture stood about fifteen hours with occasional shaking, and was then heated. The mixture was now washed out into a large platinum dish (it was neutral to test-paper), and evaporated to dryness and weighed. The weight found was 84·92 grains—a loss of 17·78 grains=32·327 grains HF present. In this experiment a small quantity of the acid vapour escaped during the weighing, which would probably account for the amount missing, viz. 0·853 grain; it was almost impossible to prevent a slight loss by this method on account of the great volatility of the acid, the carbonic anhydride carrying hydrofluoric acid with it.

I made several attempts to analyze the anhydrous acid by other means: thus, I gradually diluted the highly chilled acid, added to it an excess of a solution of acetate of lead, boiled the mixture, and filtered and washed the precipitate; the result was a failure owing to the fluoride of lead being sparingly soluble in water and in spirits of wine. In a second experiment a portion of the diluted acid was added to an excess and known weight of nitrate of lead in solution, and the mixture containing the precipitated fluoride was evaporated to perfect dryness and weighed: in this case, on evaporating the mixture, a reverse decomposition occurred; the whole of the fluoride of lead was reconverted into nitrate, and the hydrofluoric acid escaped; indeed I found by a subsequent experiment that fluoride of lead was wholly converted into nitrate by evaporation to dryness with nitric acid.

Another method I employed for analyzing the anhydrous acid was as follows. A six-ounce platinum bottle had a vertical open platinum tube about 4 inches (=10·2 centimetres) high cemented into its mouth, the tube being perfectly closed by a well-fitting plug of paraffin. The bottle was placed for a short time in a thin tin case immersed in a freezing-mixture, then taken out and weighed, and returned to the chilling-case; a small quantity of the acid, not exceeding 50 grains, was then poured into it through a long-necked platinum funnel, and the plug fixed securely and the whole reweighed. The bottle was now placed in the freezing-mixture itself at a temperature not above zero,

and distilled water added to it in minute drops at long intervals at first, until about a quarter or half an ounce had been added, taking great care not to cause an escape of vapour. A quantity of hydrate of potash, more than sufficient to convert all the acid into fluoride of potassium, was now dissolved in a separate vessel, and the solution chilled; some of this liquid, more highly diluted, was added in drops to the dilute acid, at intervals at first, and gradually the whole, taking care to cause no escape of vapour. The mixture (of strong alkaline reaction) was washed into a platinum beaker, and gradually evaporated until a film formed upon it. Precipitated silica, quite dry and perfectly pure, and especially free from matters soluble in hot concentrated sulphuric acid, was weighed in a stoppered bottle in more than sufficient quantity to convert the whole of the fluorine of the acid into tetrafluoride, the contents of the bottle added to the alkaline pasty liquid, and the bottle at once closed and reweighed. The mixture of silica and alkaline fluoride was incorporated by stirring, and an excess of concentrated sulphuric acid added gradually to it, and the mixture then heated until it was a thin liquid, and the sulphuric acid freely volatilized. The residuary mixture was then dissolved, transferred to a filter, and the silica washed, dried, ignited, transferred to a stoppered bottle and weighed. This method gave *nearly* accurate results.

The best method of analysis, however, consists in diluting the chilled acid with extreme care, and adding to it very gradually a known weight of pure caustic lime, and weighing the dried and ignited product; the following are the particulars of the process. A six-ounce platinum bottle provided with a neck about $2\frac{1}{2}$ inches ($=6.4$ centimetres) high and $\frac{1}{2}$ an inch ($=1.3$ centimetre) in diameter, with a flanged mouth, plate with paraffin layer (see page 175) and clamp screws, and previously weighed, was placed in a closely fitting tin case immersed in the freezing-mixture of ice and chloride of calcium (see page 173), and about 30 to 50 grains of the acid from a chilled and similar platinum bottle transferred to it. The bottle was then securely closed, removed from its case, and allowed to return to the atmospheric temperature and reweighed; it was now reimmersed in the freezing-mixture, and when quite cold the plate and screws were removed and *minute portions* of distilled water were allowed to drip down the inner side of the tube until the acid was sufficiently diluted to be able to add gradually in the whole about $\frac{1}{2}$ an ounce of water. Pure caustic lime (which had been repeatedly heated to whiteness until it ceased to lose weight), more than sufficient in quantity to neutralize all the hydrofluoric acid present, was now intensely heated in a small platinum box, and cooled with the lid (a closely fitting one) upon it, and weighed; the whole of the lime was then very gradually added to the dilute acid with shaking, and the mixture digested with shaking and heating until the liquid became alkaline to test-paper. On first heating, much heat spontaneously developed itself in the mixture, and required to be moderated by immersing the bottle in cold water, and *after* this development of heat the liquid was alkaline. The mixture was now evaporated and dried in the platinum bottle, then repeatedly ignited to redness and cooled until it ceased to lose weight, and finally weighed, every 22 grains increase of weight being estimated to represent 40

grains of HF present. By these means the loss of acid vapour did not exceed 0.05 grain; the residue was alkaline to test-paper, and the gain of weight found was 55 parts for every 100 parts of liquid acid taken. The following are the numbers experimentally found:—in the first reliable experiment 31.61 grains of the acid and 54.56 grains of lime were taken, and the weight of ignited residue found was 71.93 grains—a gain of 17.37 grains=31.58 grains of HF present=99.90 per cent. of HF in the acid. In another experiment 50.26 grains of the acid and 77.54 grains of lime were taken, and the weight of ignited residue was 105.18 grains—a gain of 27.64 grains=50.27 grains of HF=100.01 per cent. of HF.

In an analysis by the above process of a portion of non-rectified acid obtained from some double fluoride of hydrogen and potassium which had not been sufficiently fused, and which from the weight of acid obtained from a given quantity of the salt was suspected to contain traces of the double salt and a small quantity of water not exceeding at the utmost 3.47 per cent. (see page 176), 39.39 grains of the acid + 66.74 grains of lime gave 87.78 grains of ignited residue—a gain of 21.04 grains=38.25 grains of HF=97.09 per cent. of HF present. These results confirm all the former ones, and further support the conclusion that the liquid obtained by distilling properly prepared fluoride of hydrogen and potassium, and rectifying the product at a temperature not exceeding 100° FAHR., is anhydrous hydrofluoric acid. The lime for the above process was prepared as follows:—an excess of clear lime-water was added to a solution of nitrate of calcium, the filtered solution precipitated by a mixture of solution of ammonia and sesquicarbonate of ammonium; the precipitate was washed and dried, and repeatedly ignited to an incipient white heat in an open platinum crucible in a small gas-furnace. The presence of magnesia in the lime does not affect the numerical relation of the gain of weight to the amount of acid present. Various attempts were made to employ pure oxide of magnesium in place of the lime, but its power of neutralizing the acid was found to be too slow.

Molecular Volume of the Anhydrous Acid in the gaseous state.

I have made fourteen separate attempts to ascertain the volume of gaseous product formed by the chemical union of one volume of hydrogen with fluorine. The method I have adopted has been to heat pure anhydrous fluoride of silver to fusion in a platinum vessel containing an equivalent quantity of pure and dry hydrogen. The experiments were extremely difficult owing to the destructive nature of the substances, and the consequent difficulty of eliminating the numerous interferences which presented themselves. The following are the particulars of the method finally employed. Fragments of the purest magnesium were introduced into the neck of an inverted bottle full of previously boiled and partly cooled dilute sulphuric acid, consisting of one measure of the purest acid, and about forty or fifty of distilled water. The mixture was stirred with a rod of magnesium immediately before use. When the bottle was quite full of hydrogen, the gas was transferred to a dry bottle filled with mercury and inverted over mercury; sticks

of hydrate of potash were then agitated occasionally with the gas at intervals during several hours, and the gas transferred to a graduated tube over mercury, and allowed to remain in contact with sticks of dry phosphorus during twelve hours, the phosphorus being used to remove oxygen introduced by traces of air adhering to the vessel, &c.

About 15.3 grains of fluoride of silver of a very high degree of purity (made from pure materials, viz. hydrofluoric acid, and carbonate of silver) was placed in the previously heated and weighed platinum tube A (fig. 5), which was open at the top and closed at the bottom, and constructed without solder by the process of melting. The tube was $6\frac{1}{2}$ inches (=16.6 centims.) long and $\frac{1}{8}$ of an inch (=2.1 centims.) diameter, and had a capacity of 3.4 cubic inches (=55.716 cubic centimetres); in some of the experiments, where accurate weighing was not required, it was coated externally for about 2 inches (=5.0 centims.) in length at its closed end with a thick layer of copper by the electrolytic process: the object of coating it thus was to prevent traces of hydrogen passing through the platinum at a red heat; this may, however, be dispensed with by not applying more than a barely visible red heat in the subsequent reduction part of the process. The fluoride was now melted in it at a visible red heat until it formed a tranquil liquid, and the upper part of the tube also heated to redness to expel all moisture*. The tube was then either at once affixed to the platinum receiver (see fig. 6), or as soon as possible corked, cooled, and reweighed; the loss of weight upon the above quantity of salt was usually about 0.1 grain, arising from moisture expelled from the fluoride (which is a very hygroscopic and deliquescent substance), and partly from the moisture of the air decomposing a little of the fluoride during the fusion. The tube A was

Fig. 5.

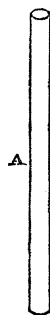

now fixed tightly upon the open bent platinum neck-tube B of the graduated platinum receiver C, and the junction made perfectly gas-tight by a small quantity of the melted mixture of sulphur and lampblack, bound over tightly by a stretched ribbon of the thinnest vulcanized india-rubber secured by string. The platinum receiver, C, was 6 inches (=15.3 centims.) long and $1\frac{1}{2}$ inch (=3.8 centims.) diameter, open and flanged at the bottom end, and formed in one piece with the bent neck B without solder. Glass receivers were found to be corroded even when thickly and carefully coated with paraffin. (N.B. They were used before I succeeded in obtaining the hydrofluoric acid in a perfectly anhydrous state.) They might perhaps be used provided moisture is perfectly excluded and the acid is *not allowed to assume the liquid state*. The entire apparatus, including A, B, and C, when put together had a capacity of about 15 cubic inches (=245.805 cubic centims.).

Fig. 6.

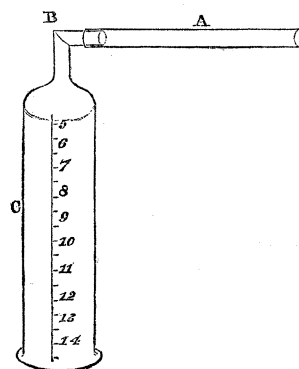

The tubes A and B were now filled as quickly as possible with dry mercury, and

* Oxide of silver was found to be decomposed at a temperature much below that of visible redness. H. ROSE states that Ag_2O begins to evolve oxygen at 250°C . (WARTS'S Dictionary of Chemistry, vol. i. p. 792).

tapped persistently to remove any adhering bubbles of air; the receiver C was then also similarly filled and tapped, and inverted over mercury in a large mercurial trough. 5.5 cubic inches (=90.128 cubic centims.) of the prepared hydrogen which had lain many hours in the measuring-tube in contact with the phosphorus was now transferred to the platinum apparatus, and the tube A inclined and persistently tapped, so as to shake out of it as perfectly as possible all the mercury. A stick of dry phosphorus was again placed in the gas for one hour to remove any oxygen introduced by adhering air-bubbles, or by air lodging in the crevice at the junction of the two tubes.

The apparatus and its contents were next removed from the mercurial trough by means of the glass vessel D, which was about 8 inches high (=20.4 centims) and 2 inches (=5.1 centims.) in diameter, and were supported within this vessel by mercury at such a height that the figure "5.5 CI" of the graduation upon the platinum-receiver coincided in horizontal position with the mark — (shown at E, fig. 7) near the top of the outer vessel. Additional mercury was now poured into the outer vessel until it attained this same indicated level at the atmospheric temperature, and was therefore at the same level inside and outside the platinum-receiver. The tube A being supported horizontally, a wet rag was now laid upon it near the sealed junction and heat applied gently to the outer end by means of a spirit-lamp until a barely visible redness was attained, this being quite sufficient to melt the enclosed fluoride of silver. This degree of heat was maintained about one hour, and near the termination of the heating-process a much higher and variable temperature was applied for a short time, but not sufficiently high to melt the reduced silver. The mercury in the outer vessel was kept at the original level during the heating-process &c., by raising or lowering the platinum apparatus as occasion required. The whole apparatus was then placed in a suitable air-bath, and gradually heated to a uniform and constant temperature of about 212° FAHR. (=100° C.), a thermometer being placed in the vessel of mercury D, and another near it in the air-bath. The platinum apparatus was raised gradually as the gas expanded, to keep the mercury at the original level, and the volume of enclosed gas was noted at the various temperatures.

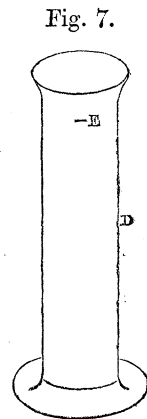

In each instance, during the decomposition of the silver-salt by the hydrogen, after the first expansion (produced by the heat) a very large *reduction* of volume occurred; for instance, 10.0 cubic inches (=163.87 cub. centims.) were reduced to 6.5 (=106.5 cub. centims.); and on removing the lamp and allowing the whole apparatus to cool to 50 or 60° FAHR. (=10° to 15° C.), a still further and very large contraction invariably occurred; for instance, 6.5 cubic inches (=106.5 cub. centims.) became 3.0 cubic inches (=49.161 cub. centims.), even while under a rarefaction of 5 inches (=12.75 centims.) height of mercury. Similar contractions [to very small volumes at the atmospheric temperature took place in all the experiments. These reductions of volume were in the earlier trials somewhat due to small quantities of air present, the oxygen of which formed water with some of the heated hydrogen and condensed a little

of the acid vapour. In all cases, however, the contraction of volume was evidently nearly wholly due to the partial condensation of the hydrofluoric-acid vapour within the vessel to a liquid state. This liquid could not of course be seen on account of the opacity of the apparatus, and being very minute in amount (probably less than half a drop for each cubic inch (=16.387 cub. centims.) of hydrogen employed) and very volatile, it was in all cases instantly converted into a dense fume on opening the vessel. The mere warmth of the hand was sufficient to make the partly liquefied acid expand very greatly. These results of contraction agree with and confirm the results already found in my experiments, viz. that anhydrous hydrofluoric acid is a very volatile liquid at 60° FAHR.

The following are the actual results obtained in one of the first reliable approximate experiments. Six cubic inches (=98.322 cub. centims.) of prepared hydrogen at 50° FAHR. and 16.4 grains of fused fluoride were employed. During the first three minutes of heating, the gas expanded to 7.8 cubic inches (=127.8 cub. centims.). Contraction then commenced and continued during about twenty-five minutes, the volume being gradually reduced to about $4\frac{1}{2}$ cubic inches (=73.74 cub. centims.). The heat was continued about half an hour longer, and the apparatus then, whilst still warm, placed in the air-bath, and heated gradually to a fixed temperature of 200° FAHR.; the volume of gas was then 14.5 cubic inches (=237.61 cub. centims.) = 11.2 cubic inches (=183.53 cub. centims.) at 50° FAHR. The rate of expansion was somewhat greater at the higher degrees of temperature than at the lower ones; for instance, at 139° FAHR. the volume was 12.1 cubic inches, at 160° FAHR. 12.85, at 186° FAHR. 14.0. Only a minute quantity of undecomposed silver fluoride was found after the experiment.

In another experiment, with 5.5 cubic inches (=90.128 cub. centims.) of hydrogen at 50° Fahr. and standard pressure, and 15.3 grains of fluoride, on applying heat the gas expanded to 7.3 cubic inches (=119.625 cub. centims.) at the end of three minutes; it then gradually contracted during the next twenty minutes to about 4.2 cubic inches (=68.825 cub. centims.); the heat was continued about twenty minutes longer with occasional heating to full redness (but not sufficient to fuse the enclosed reduced silver). The apparatus was then at once transferred to the hot air-bath, and heated gradually to 212° Fahr., and kept at that temperature some time. The volume of gas thus found was 12.8 cubic inches (=209.75 cub. centims.) at 176° FAHR., 13.0 (=213.03 cub. centims.) at 184° FAHR., and 14.0 (=229.418 cub. centims.) at 212° FAHR.; the latter number, after correction for the amount of displacement of the level of the mercury by the thickness of the sides of the platinum vessel between "5.5," the original depth of immersion, and "14" the final one, was 14.3 (=234.33 cub. centims.); this is equal to 10.84 cubic inches (=177.635 cub. centims.) at 50° FAHR., the theoretic quantity required being 11.0 inches (=180.257 cub. centims.). On cooling the apparatus to 50° FAHR., the mercury rose and filled the platinum tube to within about 0.7 cubic inch (=11.77 cub. centims.) of its capacity, even whilst under rarefaction by a column of mercury about 3.5 inches (=8.9 centims.) in height. Minute traces only of undecomposed fluoride of silver were found in the tube after the experiment.

From the results obtained, it appears that one volume of hydrogen in uniting with fluorine, produces not simply one volume of gaseous product as it does when uniting with oxygen, but two volumes, as in the case of its union with chlorine.

According to M. PRAT* anhydrous fluoride of silver contains oxygen, its constitution being 1 equiv. of fluorine = 29.6, 1 equiv. of oxygen = 8, and 2 equivs. of silver = 216. The results obtained in these experiments contradict this view; for according to it the volume of gases obtained should have been less, as 1 volume of hydrogen in uniting with oxygen produces only 1 volume of gaseous product.

To obtain a numerical result more nearly approaching theoretical accuracy than in the foregoing experiments, various minute corrections would have to be applied:—1st, for the increased capacity of the platinum apparatus caused by its expansion by heat; 2nd, for the rise of level of the mercury caused by its expansion by rise of temperature; 3rd, for the lowering of the said level by expansion of the glass containing-vessel; 4th, for the rise of the said level caused by the immersed bulb of the thermometer; 5th, for the variation of atmospheric pressure during the experiment; and 6th, for the meniscus, &c.

To ascertain the loss of weight by the fluoride of silver in the preceding experiments, 12.8 grains were put into a platinum boat enclosed in a roll of platinum-foil, and heated to tranquil fusion at a gentle red heat in a platinum tube-retort (similar to the tube A in fig. 5), then cooled and weighed; the loss was 0.10 grain. The boat and foil were now put into a long horizontal platinum tube and gently heated in a slow current of hydrogen (which had been generated by magnesium and pure dilute sulphuric acid, and dried by two wash-bottles of strong sulphuric acid), the current of gas and the heat being maintained until acid fumes entirely ceased; the loss of weight was 1.80 grain. This is less than the theoretic quantity by 0.10 grain, which is partly (if not wholly) accounted for by the fact that fluoride of silver, even when carefully prepared from pure materials, is liable to contain a variable amount of metallic silver, which is left as an insoluble black powder on dissolving the salt in water. This free silver is caused in the process of drying the salt, by the aqueous vapour from the imperfectly dried portions and from the surrounding air decomposing the dry and hotter portions; it is increased in quantity every time the salt is fused in contact with atmospheric air.

[To determine the amount of silver in the fluoride, 15.89 grains of perfectly anhydrous fluoride was dissolved in water, the solution filtered, the separated black precipitate washed, and the silver in the filtrate determined by addition of chloride of potassium; it gave 18.00 grains of chloride = 13.55 grains of silver. The black matter weighed 0.1 grain after ignition; deducting this amount, the 15.79 grains of fluoride contained 13.55 grains of silver: theory requires 13.437 grains. On several occasions I have had reason to suspect a slight degree of solubility of the separated and finely divided metallic silver in a strong aqueous solution of silver fluoride, similar to that of lead and silver in strong aqueous solutions of their respective nitrates; and if this be correct it may account for

* Comptes Rendus, No. 9, August 1867.

the slight excess of silver found in this determination. The amount of fluorine in the filtrate was determined by means of a solution of calcium salt in the usual manner; it gave 4.40 grains of fluoride of calcium = 2.1436 grains of fluorine, the quantity required to complete the weight being 2.24 grains. In my hands this process of determining the amount of fluorine has not hitherto yielded very accurate results.—Received January 9, 1869.]*

These results, combined with the foregoing experiments on molecular volume, agree with the conclusion that a volume of hydrogen weighing 1 unites with 19 parts by weight of fluorine to form 2 volumes of hydrofluoric acid, and that the specific gravity of gaseous anhydrous hydrofluoric acid is ten times the amount of that of hydrogen.

The acid vapour obtained by heating fluoride of silver in the closed vessel of hydrogen over mercury, as already described, was transferred to glass vessels over mercury; it was colourless, and quite transparent; it did not corrode the glass vessels or render them dim in the slightest degree during several weeks, provided moisture was entirely absent, but if there was the slightest trace of damp present the surface of the glass soon lost its brightness. A fragment of ice introduced into the gas instantly caused the surface of the glass near it to become corroded and opaque white. The vapour of hydrofluoric acid escaping at any minute orifice from a vessel of the dry acid, condenses moisture rapidly upon the contiguous parts of the vessel.

FREMY sought for oxygen in the anhydrous acid, but was unable to find any†. Sir H. DAVY also, who prepared his acid by distilling fluor-spar with sulphuric acid containing not more than 1 equivalent of water, could find no oxygen in it, either by electrolysis, or by neutralizing it with gaseous ammonia; but when the sulphuric acid he employed contained more than 1 equivalent of water, he found water in the hydrofluoric acid. The acid obtained in my experiments also I consider to be destitute of oxygen, not only from the results obtained in the various analyses and experiments already described, but also, 1st, because the double fluoride of hydrogen and potassium from which the acid was prepared, when fused and electrolyzed with platinum electrodes, evolved abundance of inflammable gas at the cathode, but yielded no gas at the anode, although oxides are by electrolysis decomposed before fluorides; 2nd, the electrolysis of the anhydrous acid with platinum electrodes yielded no odour of ozone, whereas hydrofluoric acid containing various percentages of water evolved that odour strongly (see page 199); 3rd, the properties of hydrofluoric acid prepared by heating pure fluoride of silver in pure hydrogen (see pages 181 & 182) agreed in properties, as far as those properties were ascertained, with the acid obtained from the double salt; and 4th, because two volumes of gaseous anhydrous hydrofluoric acid were produced by the reaction of one volume of hydrogen upon its equivalent of fluoride of silver, whereas if

* Note, added May 25, 1869. I have since, by repeated and more accurate analyses, confirmed the composition of the recently fused salt to be wholly silver and fluorine, with a small quantity of enclosed metallic silver.—G. G.

† Comptes Rendus, February 27th, 1854.

oxygen had been present, less than two volumes of acid gas would have been produced. All the results also support the conclusion that the acid obtained by heat from the double fluoride, and that from pure fluor-spar and mono-hydrated sulphuric acid heated together in a platinum retort, is free from oxygen and water. The complete synthesis of the acid can only of course be performed by means of hydrogen and free fluorine.

To determine the specific gravity of the anhydrous acid, I employed a thin platinum bottle of the form and size of the annexed sketch (fig. 8); with the stopper in its place the bottle contained 1000 grains of distilled water at 60° FAHR. The stopper had a minute tube up its centre, and also two funnel-shaped cavities, one at each end, as shown in the sketch. A thin platinum wire was also soldered round the stopper to form a

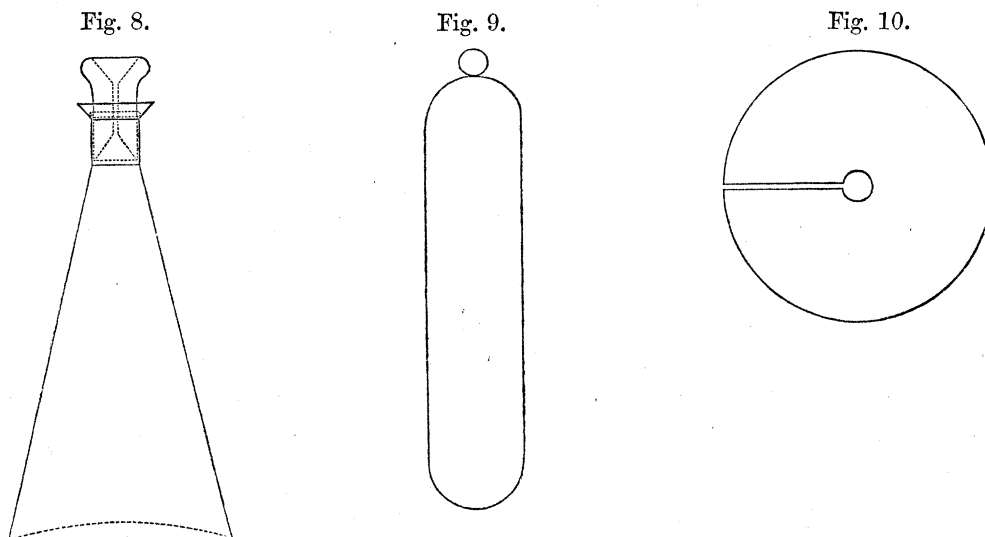

shoulder, which rested upon the neck of the bottle when the stopper was tightly down in its place. A specific-gravity bottle made of gutta percha would not resist the action of the acid. Sponge was employed to absorb the excess of acid around the stopper. The specific gravity found of the pure rectified acid in two separate experiments was 0.9885 at 56° 5 FAHR., that of water being =1000; whilst that of a less pure sample was 1.036 at 60° FAHR. (Sir H. DAVY found 1.0609). These results are not perfectly accurate, owing to the unavoidable escape of acid vapour, but the amount of error is probably not more than 1 part in 1000. The specific gravity of the pure rectified acid was also found by weighing a platinum tube (which had been previously filled with paraffin by fusion) separately in the acid and in distilled water, both at 52° FAHR.; the number found was 0.9922, assuming that of water to be =1000 at 52° FAHR. By weighing a closed platinum vessel of the annexed size and form (fig. 9) separately in the acid and in distilled water, both at 55° FAHR., the specific gravity found was as 0.9879 is to 1.0000; this result is the most accurate one obtained: the pure acid is therefore a little lighter than water. The vessel containing the acid was covered by a thin plate of paraffin of the annexed form (fig. 10) during the weighing.

The acid obtained in my experiments was much more volatile than sulphuric ether. I ascertained its boiling-point as follows. A platinum bottle, A (fig. 11), of about $2\frac{1}{2}$ ounces capacity, had a platinum angle-tube, B, which fitted tightly into its neck; the angle-tube had a short open tube, C, within which a platinum tube, D, was tightly fitted and luted with the melted sulphur mixture (see page 173); this tube was open at its upper end and closed at its lower end, and was for the purpose of receiving a thermometer. About two ounces of the perfectly pure and previously chilled acid was poured into the chilled bottle A, the angle-tube inserted and luted securely with paraffin, the smaller end of the angle-tube fixed within the platinum tube of a LIEBIG'S condenser (with freezing-mixture, see page 173) and luted with the paraffin mixture. A platinum bottle was affixed to the condenser to receive the distillate. The bottle was now immersed in a small water-bath, a thermometer placed in the water, another within the tube in the acid, and heat very gradually applied to the water. The acid boiled at 67° FAHR., the mercury of the inner thermometer remaining stationary at that point, and that of the outer one at about 77° FAHR., until nearly all the acid had passed over. By applying a stethoscope to the end of the inner tube D, the boiling could be feebly but distinctly heard; a slight escape of fume at the exit-tube of the receiving-bottle (see page 174) commenced with the boiling, continued with it, and ceased when the boiling ceased. At -30° FAHR. ($= -34\frac{1}{2}^{\circ}$ C.) the acid is still a perfectly mobile liquid, fuming but little in a narrow-necked bottle, and its solidifying point is probably very many degrees below this (see also page 198).

The vapour-tension of the acid at 60° FAHR. is very considerable, and an experiment was made in the following manner to approximately determine the degree of pressure to which the bottles containing the acid were subjected at ordinary temperatures. A six-ounce platinum bottle containing between four and five ounces of the anhydrous and pure acid in a chilled state was connected air-tight, by means of the platinum angle-tube A (fig. 12), with an inclined platinum tube B, about 16 inches ($=41.7$ centims.) long and $\frac{2}{3}$ of an inch ($=0.95$ centim.) diameter, and a vertical bent and open glass tube C, about 30 inches ($=76.25$ centims.) high and $\frac{1}{8}$ of an inch ($=0.32$ centim.) bore, the bent portion of the tubes being filled to about 6 inches ($=15.3$ centims.) in height with mercury. The bottle was now gradually allowed to attain a temperature of 60° FAHR. At that temperature the difference of level of the mercury in the two tubes was $15\frac{1}{2}$ inches ($=39.4$ centims.), and therefore the pressure upon the interior of the bottle was $=7.58$ pounds per square inch. No leakage occurred at the cemented joints. The results of this experiment, together with those of the previous ones, show the necessity of keeping the

Fig. 11.

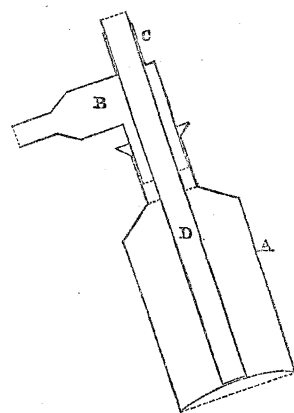
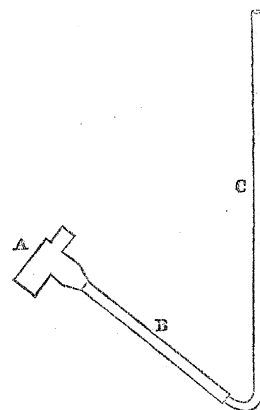

Fig. 12.



acid in a cool place. On loosening the lid of a bottle of the acid at 60° FAHR., the acid vapour is expelled in a jet like steam from a boiler.

The low boiling-point, the extremely dangerous and corrosive nature of the acid, and its great affinity for water, illustrate the very great difficulty of manipulating with it and retaining it in a pure state; nevertheless by the contrivance described (see page 175), and placing the bottles containing it in a cool cellar (never above a temperature of 60° FAHR.), the author has succeeded in keeping the liquid acid perfectly, without loss, and unaltered through the whole of the recent hot summer.

The following is the order of electrical relation found with different metals &c. in the pure anhydrous acid at 0° FAHR.:—zinc, tin, lead, cadmium, indium, magnesium, cobalt, aluminium, iron, nickel, bismuth, thallium, copper, iridium, silver, gas-carbon, gold, platinum, palladium. The acid in these experiments was contained in a covered deep and narrow platinum cup placed in a tin chilling case immersed deeply in the freezing-mixture.

Sir H. DAVY electrolyzed the liquid acid prepared by distilling fluor-spar with strong sulphuric acid. He cemented a platinum wire by fusion into a cup of horn silver, and inverted the cup in the acid in a tray of platinum. He used a very weak voltaic current, and kept the apparatus cool by a freezing-mixture. The platinum wire rapidly corroded and became covered with a chocolate-coloured powder. Inflammable gas like hydrogen was evolved from the cathode. He also tried a plumbago anode, but it was quickly destroyed and the liquid became turbid and black; also a charcoal anode upon the end of a platinum wire; the charcoal absorbed the acid and made the platinum wire the pole*. G. J. KNOX† also electrolyzed hydrofluoric acid with a charcoal anode attached to a platinum wire, and a platinum wire cathode, in a vessel of fluor-spar half filled with the acid, and having a perforated stopper of the same spar dipping into the acid. It is not stated in the above paper how the acid was prepared or its purity determined, nor by what means charcoal capable of resisting the acid was obtained.

I have made numerous experiments of electrolyzing the pure anhydrous acid with various electrodes. The method adopted in many of the experiments was to place a platinum cup about $3\frac{1}{2}$ inches (=9 centims.) deep and $1\frac{3}{4}$ inch (=4.5 centims.) wide in a tin case (weighted with lead) in the freezing-mixture; the cup was about half filled with the acid, and was closed by a well-fitting stopper of paraffin, through the centre of which a long rod or plate of the substance constituting the anode was closely fixed, the cup itself being the cathode; a loosely fitting cup of paraffin about half an inch deep, and provided with a handle, was immersed in the acid beneath the anode to collect particles which fell from the anode, and to prevent hydrogen ascending from the bottom of the platinum vessel and coming into contact with the positive electrode. The following are some of the results obtained. The liquid acid conducted with a platinum anode much more readily than pure water; with four SMEE'S elements it began to visibly

* Works of Sir H. DAVY, vol. v. p. 416.

† Philosophical Magazine, 3rd series, vol. xvi. p. 192.

conduct, and with ten elements it conducted readily. No odour of ozone was evolved, and the platinum anode gradually acquired a thick red-brown crust. By employing forty SMEE'S elements the conduction was copious; the anode rapidly corroded, and much finely divided platinum as a greyish-black powder collected in and beneath the paraffin cup; this powder appeared to be due to detached particles of the red-brown crust becoming reduced by the diffused bubbles of free hydrogen from the cathode, or was composed of particles of metal mechanically detached from the anode by the current. Portions of the soft earthy crust were scraped off at intervals into a platinum dish upon a heated slab of iron; it dried to a dark-brown earthy salt (doubtless fluoride of platinum), which rapidly deliquesced in the air to a tenacious sticky mass, similar to damp fluoride of silver: the anhydrous platinum compound was perfectly insoluble in the acid, but formed a blood-red liquid (like a solution of tetrachloride of platinum) with cold water, and the dilute aqueous solution, when heated, became full of flocks by separation of an insoluble basic salt. By far the greater portion of the platinum compound detached itself from the anode and became reduced to the metallic state, and only a small amount was left upon the anode as a soluble salt. The whole of the powder in the paraffin cup was found by appropriate tests to be metallic platinum. With an anode of very close-grained gas-carbon and six SMEE'S elements, conduction occurred freely, and in less than half an hour nearly half the thickness of the carbon rod was disintegrated and fell as a loose powder to the bottom of the vessel. Numerous attempts were made to electrolyze the acid with a charcoal anode; fifteen different kinds of wood, including some of the densest kinds, were converted into charcoal by very gradual drying and equally gradual heating to full redness in a copper tube retort until all evolution of gas ceased. Some of the resulting rods were exceedingly hard and dense, and emitted a clear metallic ringing sound when struck; the denser kinds, especially those free from cracks, conducted freely even with ten SMEE'S elements. The best kinds were those made from kingwood, beech, ebony, lignum-vitæ, and boxwood; that from lignum-vitæ was nearly as hard as baked earthenware*. On immersing either of the rods in the acid, even without passing an electric current, it soon began to crack and fly to pieces, and on passing the current the rods commenced breaking immediately, and in some instances with dangerous violence, projecting fragments to a considerable distance; even the hardest and densest kinds of charcoal behaved thus and became brittle throughout the immersed parts; the most resisting kind was that made from beechwood. The number of SMEE'S elements employed varied from ten to fifty-six, and the kind of electrolysis-cell used was that represented by figure 13 (see page 189). The cracking of the charcoal was attended by evolution of numerous bubbles of gas (probably air previously absorbed by the carbon); on this account, and also in consequence of the fume developed by the heat of conduction-resistance in the charcoal, it was difficult to ascertain if the anode evolved gas due to electrolysis; nevertheless, with the aid of a strong light and watching

* For the preparation of articles and vessels of charcoal for these experiments, see *Philosophical Magazine*, September 1868.

for opportunities, it was found that the passage of the current was *not* attended by any distinct increase of gas from the anode. No special odour could be detected above the anodes, but on removing the charcoal from the liquid it evolved a feeble odour somewhat like that of chlorine, in addition to the intense one of the acid. The kinds of wood employed for making the charcoal were beech, kingwood, ebony, lignum-vitæ, box, mahogany, zebra, Memel oak, English oak, rosewood, maple, lancewood, walnut, Norwegian pine, and ironwood. The fracture of the carbons was not caused by the lowness of the temperature of the acid.

With an anode of pure sheet gold the acid scarcely conducted at all, except for a short time, even with forty SMEE'S elements; by continuing the action about $1\frac{1}{2}$ hour, the anode acquired a dark reddish-brown film and a few crystals upon its edges, which were at first of a green colour, but became red by exposure to the air. With a palladium anode the acid conducted somewhat less freely than with one of platinum or gas-carbon; and by employing forty SMEE'S elements the palladium anode was also corroded. The salts which fall off the anodes appear to be wholly converted into metal by the disseminated minute bubbles of hydrogen, and even some of the coating of the anode itself is partly so converted if the hydrogen is allowed to come into contact with it. The action in the electrolysis-cell was sometimes watched by the aid of a magnesium light, as the fume was usually too dense to admit of inspection by ordinary light.

The most effective form of electrolytic apparatus employed is represented by the annexed figure. A A is a circular and deep platinum cup; B B is a shallow and loosely fitting cup of paraffin provided with a handle (not shown); C C is a wide tube of platinum open at both ends, and fixed at its upper end within an equally wide circular perforation in the annular paraffin stopper, D D; E E is an inner stopper of paraffin fitting within the other, and supporting a sheet of platinum or other metal, F F, which passes through it and constitutes the anode. The use of the tube C C is to prevent the hydrogen evolved at the inner surface of the cathode, A A, coming into contact with the anode, F. The tube C C is coated on its outer side at its lower end and up to a short distance above the level of the liquid with a thin layer of paraffin, to prevent the tendency of electrolytic action upon the tube C C. Electrolysis tends to first decompose any traces of water the acid may contain, and thus maintain the acid in an anhydrous state.

Fig. 13.

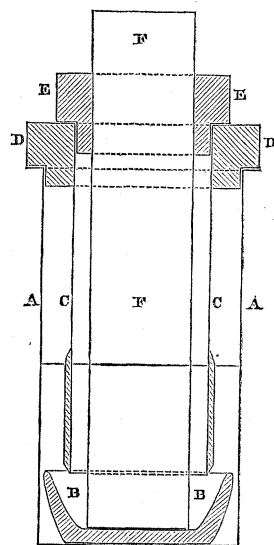

Two ounces of strong sulphuric acid was added to a mixture of 336 grains of pure fluoride of sodium and 472.5 grains of nitrate of potassium, both in fine powder, in a platinum retort, the mixture distilled, and the product received in a platinum bottle. The distillate weighed 678.2 grains, it should have weighed only 664 grains; the excess was probably water, from the sulphuric acid not being of maximum strength. In applying the heat, the retort was immersed in a bath of linseed-oil, the temperature of which

was not raised above 450° FAHR. No permanent gas was evolved during the process. The product was a colourless fuming liquid, much less fuming than anhydrous hydrofluoric acid, and did not corrode paraffin or platinum, but corroded vulcanized india-rubber rapidly. This liquid was electrolyzed by means of six SMEE's elements and two large platinum electrodes, during five hours, the liquid being in a covered narrow and deep platinum cup immersed in a freezing-mixture; conduction occurred freely, and an odourless gas (doubtless ordinary oxygen) was freely evolved from the anode; the anode was not corroded, and both electrodes were unaltered in weight.

520 grains of anhydrous hydrofluoric acid was distilled from about 2000 grains of KF, HF in a platinum retort through a platinum tube surrounded by the freezing-mixture into a platinum bottle (surrounded by the same mixture) containing 334.17 grains of fibrous sulphuric anhydride; the first contact of the two substances was attended by a hissing sound and evolution of great heat, and the resulting compound was a colourless liquid, of a less fuming character than either of the two substances alone. In this experiment it was necessary to cement the junctions near the receiver with the melted sulphur mixture (see p. 173), as paraffin is rapidly blackened by the vapours of sulphuric anhydride*. The compound formed in this case was probably analogous in some respects to partially hydrated sulphuric acid, 2HF taking the place of H_2O , and corresponds to the third hydrate of sulphuric acid, or $\text{H}_2\text{SO}_4, 2\text{H}_2\text{O}$. This liquid was also electrolyzed by means of platinum electrodes and ten SMEE's elements; the conduction was moderate (less than with HF alone), and the anode was corroded. Sulphuric anhydride added to the mixture produced heat.

To obtain an idea of the *general* chemical behaviour of the pure anhydrous acid, numerous substances (generally anhydrous) were immersed in separate portions of it in platinum cups, contained in a tin chilling-case sunk deep in the freezing-mixture (see p. 173), and sometimes covered with plates of transparent fluor-spar†; the temperature of the acid varied from 20° to 0° FAHR. It slightly dissolved bromine to a liquid of an orange colour; iodine, carbon, boron, silicon, sulphur, selenium, tellurium (in powder), and phosphorus were unchanged. The noble and base metals were unaffected; and even magnesium, aluminium, zinc, cadmium, tin, lead, reduced iron, arsenic, antimony, and bismuth in a state of fine powder did not cause any evolution of hydrogen. Sodium and potassium behaved much the same as with water, the latter producing vivid combustion. Nearly all the salts of the alkali and alkaline-earth metals produced strong chemical action. The acid produced violent chemical action with the following anhydrides:—fused boracic, silicic (only when in fine precipitated powder, not with small granules of quartz or even with fine white sand), sulphuric, phosphoric, molybdic, vanadic, and niobic anhydrides; selenious and arsenious anhydrides dissolved freely; antimonious, tungstic, and titanitic anhydrides were either but little or not at all affected nor dissolved;

* Gun-cotton inflamed by contact with sulphuric anhydride.

† I have obtained suitable vessels, plates, and stoppers of fluor-spar of Mr. J. TYM, Speedwell Mine, Castleton, Derbyshire.

chlorochromic acid would not mix with the acid. With concentrated nitric and sulphuric acids the acid mixed quietly, but with strong hydrochloric acid it produced active effervescence. With lime, baryta, strontia, and the hydrates of soda and potash it united powerfully, and with magnesia less strongly. No effect occurred with the peroxides of silver, iron, lead, thallium, or manganese; nor with the suboxide or protoxide of copper, the oxides of nickel, cobalt, tin (both oxides), or cerium. Teroxide of antimony, bismuth, and the oxides of silver, glucinum, and lanthanum produced strong chemical action, but did not dissolve. The oxides of mercury (both) and lead (both) were changed to fluorides, and apparently also were oxide of zinc and peroxide of barium, the latter with most violent action (probably water was present). Bin oxide of platinum was slightly dissolved, and the oxides of uranium and chromium freely; chemical changes also occurred with the lower oxides of vanadium and titanium, and with alumina. The nitrates of lead, uranium, strontium, and barium exhibited no strong chemical action, and did not dissolve, but signs of free nitric acid appeared; nitrate of silver was unaffected (?), nitrate of potassium dissolved freely with a hissing sound; nitric acid was found, by suitable tests, to be set free with the nitrates of lead, barium, and potassium. The fluorides of antimony, bismuth, mercury, copper, nickel, cobalt, iron, lead, tin (both), cadmium, zinc, manganese, cerium, aluminium, magnesium, and calcium were either slightly or not at all affected, and did not dissolve; the fluorides of uranium and chromium exhibited chemical change and dissolved. Alkaline fluorides were strongly affected; the fluorides of silver, barium, and lithium, also cryolite, hissed strongly but did not dissolve; and those of thallium, strontium, sodium, potassium, rubidium, and ammonium produced different degrees of violent chemical action and solution; the acid fluoride of potassium also produced strong action and solution: the behaviour of the alkaline fluorides with the anhydrous acid may be compared to that of the alkaline oxides and hydrates with water. Solid terchloride of carbon, and the chlorides of silver, mercury (both), copper, nickel, cobalt, lead, cadmium, manganese, and the violet sesquichloride of chromium were undissolved and unaffected; the liquid tetrachloride of carbon, and the liquid chlorides of sulphur, phosphorus, arsenic, and tin would not mix with the acid, whilst the liquid perchloride of antimony and tetrachloride of titanium were decomposed with violent action and formation of deliquescent solid residues, as when water is added to them; the solid perchloride of phosphorus was also violently decomposed and a white powder formed; the chlorides of calcium, barium, lithium, sodium, potassium, and ammonium were decomposed with strong action and effervescence, the latter four with solution and especially strong action. The chlorates of sodium and potassium were rapidly decomposed with evolution of yellow fumes of peroxide of chlorine; no visible effect occurred with the chlorate of barium or perchlorate of potassium. Terbromide of antimony turned white, as on addition of water, and did not dissolve; the bromides of zinc and cadmium were but little affected; the bromides of calcium, barium, and potassium were decomposed with strong effervescence, and the latter bromide dissolved; bromate of potassium was also rapidly decomposed with copious liberation of bromine. The ter-

iodides of arsenic and antimony, the tetraiodide of platinum, iodide of silver, biiodide of mercury, subiodide of copper, and the iodides of lead, cadmium, and zinc were unaffected, whilst the iodides of calcium, barium, sodium, and potassium were strongly decomposed, and iodine freely liberated in the first three instances. Iodate of potassium also exhibited some chemical action, but no iodine was set free. The acid decomposes all carbonates; the anhydrous carbonates of silver, copper, cobalt, lead, cadmium, zinc, manganese, calcium, strontium, barium, lithium, sodium, potassium, and ammonium were all decomposed with effervescence; those of the alkali and alkaline-earth metals exhibited violent action. Fused borax and the borate of ammonium produced powerful chemical action. The boro-fluorides of sodium and potassium were unaffected. Glass was rapidly corroded. (N.B. It was not corroded in the *gaseous* acid: see page 184.) The silico-fluorides of sodium and potassium dissolved with effervescence; titanio-fluoride of potassium also dissolved with strong action. Carbonic bisulphide would not mix with the acid; the acid had also no chemical or solvent effect upon the sulphides of arsenic (both), antimony (the black sulphide), palladium, mercury (vermilion), copper (subsulphide), iron (both), lead, tin (the bisulphide), cadmium, zinc, and molybdenum; the sulphides of calcium, barium, sodium, and potassium were violently decomposed with evolution of sulphuretted hydrogen, and in the latter instance with separation of liquid sulphur. Bisulphite of sodium dissolved with effervescence. Sulphate of cobalt was unaffected; the sulphates of calcium, strontium, and barium partly dissolved with a hissing sound; sulphate of sodium and acid sulphate of potassium exhibited strong action and dissolved. Chrome-alum dissolved quietly to a purple liquid, and sulphate of ammonium to a colourless liquid. Phosphide of copper was unaffected; phosphide of calcium was powerfully decomposed; phosphate of copper was also decomposed; phosphate of uranium produced action; phosphate of calcium was partly dissolved, and phosphate of ammonium completely. Arsenite of copper was decomposed; arsenite and arseniate of ammonium, and the arseniate of magnesium and ammonium, produced violent action; the first and third were dissolved. Damp crystals of permanganate of potassium hissed and dissolved to a deep-green liquid. Red chromate of lead became yellow and partly dissolved; yellow chromate of lead dissolved to a yellow liquid; the mono-chromates of sodium and potassium, and the acid chromates of sodium, potassium, and ammonium dissolved with violent action to blood-red liquids, with evolution of vapour of fluoride of chromium; vanadate and metavanadate of ammonium produced powerful action, the former partly, and the latter wholly dissolving to yellow liquids. Native molybdate of lead was unaffected; molybdate of ammonium produced strong action but did not dissolve. The tungstates of sodium and ammonium were violently decomposed, the former dissolved, and the latter remained insoluble. Cyanide of mercury was partly dissolved; cyanide of potassium was violently decomposed with liberation of hydrocyanic acid; anhydrous ferrocyanide of potassium dissolved with violent action, and the solution became milky on addition of water; ferricyanide of potassium dissolved to a yellow liquid, and nitrocyanide of titanium was unaffected.

The acid mixed with pyroxylic spirit with strong action, and with ether and alcohol.

Oxalic acid, oxalate, and benzoate of ammonium were but little affected. Paraffin was unaffected. Benzole would not mix with the acid. Spirit of turpentine exploded and produced a blood-red liquid. Gutta percha, india-rubber, ebonite, parkesine, white wax, sealing-wax, gum-arabic, amber, copal, dammar, gamboge, juniper, kino, kowrie, shellac, and ordinary resin were rapidly disintegrated, and in nearly all cases quickly dissolved to red liquids. Spermaceti, stearic acid, and myrtle wax were but little affected. Caffeine, indigo, sugar of milk, and cane-sugar dissolved freely and rapidly. Gun-cotton dissolved instantly to a colourless liquid, which left an inflammable film on evaporation. Silk also instantly dissolved to a glutinous colourless liquid. Paper, cotton-wool, calico, gelatine, and parchment were instantly converted into glutinous substances and dissolved. Horn instantly expanded to a bulky white mass. Irish moss, German-tinder, and flannel were less rapidly affected, and sponge was less affected than any other porous organic substance. Pine-wood instantly blackened.

The chemical behaviour of such of these numerous substances with the anhydrous liquid acid as have been further examined will be more fully described in their respective places.

The *gaseous* acid carbonized cork, and acted upon wood, paper, gutta percha, india-rubber, vulcanized india-rubber, and bees-wax more slowly, but in much the same manner as the liquid acid; sealing-wax absorbed the gas and became soft and disintegrated. It did not act upon carbon, sulphur, or selenium, nor, if perfectly dry, did it act upon glass, as has been already stated (see pages 184 & 192).

From the various experiments already described, we may conclude that hydrofluoric acid is by its properties placed between hydrochloric acid and water, but is much more closely allied to the former than to the latter. It is more readily liquefied than hydrochloric acid, but less readily than steam: like hydrochloric acid it decomposes all carbonates; like water it unites powerfully with sulphuric and phosphoric anhydrides, with great evolution of heat. The fluorides of the alkali metals unite violently with anhydrous hydrofluoric acid, like the oxides of those metals unite with water; the hydrated fluorides of the alkali metals also, like the hydrated fixed alkalies, have a strongly alkaline reaction, and are capable of expelling ammonia from its salts. It may be further remarked that the atomic number of fluorine lies between that of oxygen and chlorine; and the atomic number of oxygen, added to that of fluorine, very nearly equals that of chlorine.

B. *Aqueous Hydrofluoric Acid.*

Ordinary hydrofluoric acid is very impure; it usually contains large quantities of sulphuric acid (distilled over by excess of heat), much sulphurous acid (from action of the oil of vitriol upon the iron retort), some hydrofluosilicic acid (from silica in the spar), arsenic (from the sulphuric acid), and small amounts of hydrochloric acid, iron, lime, and other fixed matters. A sample manufactured in Birmingham, of specific gravity 1.399, was found by analysis to contain 29.58 per cent. of H_2SO_4 , and 0.5 per cent. of ignited fixed matter which had been previously precipitated by excess of ammonia; it

also gave 4.08 per cent. of yellow sulphur (containing arsenic) by decomposing the sulphurous acid in it by an excess of sulphuretted hydrogen. A second sample, sent to me by the same makers, had a specific gravity of 1.310, and contained 4.8 per cent. of H_2SO_4 . A third sample, made near Birmingham, of specific gravity 1.217, contained 3.27 per cent. of H_2SO_4 and 2.16 per cent. of ignited fixed matter precipitated by ammonia, including 0.76 per cent. of silica = 1.824 per cent. of 2HF , SiF_4 . A fourth sample, obtained from Wolverhampton, of specific gravity 1.1097, contained 0.55 per cent. of H_2SO_4 . A fifth, obtained from London, of specific gravity 1.1894, contained 10.54 per cent. of H_2SO_4 . A sixth, from GÖRLITZ, in Prussia, of specific gravity 1.1741, contained only traces of sulphuric acid. A seventh, from Mr. HORNBY, of Sheffield, of specific gravity 1.188, contained traces only of sulphuric, hydrochloric, or hydrofluosilicic acids, or of fixed matter. And an eighth sample, from Mr. WILLIAM COLLIER, Sheffield, of specific gravity 1.248, contained no sulphuric or hydrochloric acid, and left only a trace of solid residue on evaporation to dryness: by neutralization with ammonia, 1.70 per cent. of fixed matter was obtained after washing and ignition; this fixed matter contained 1.46 part of SiO_2 = 3.5 per cent. of 2HF , SiF_4 in the acid; the fixed matter also contained iron, &c. A second sample, weighing twelve pounds, from the same maker gave 723 grains of sulphur by treatment with excess of sulphuretted hydrogen. All the samples contained large but variable amounts of sulphurous acid, and gave copious deposits of sulphur &c. by treatment with excess of sulphuretted hydrogen; they also contained very variable percentages of HF , varying from about 10 to 70. Oil of vitriol is sometimes added to weak hydrofluoric acid to enable it to etch glass in a suitable manner; it imparts to it a fictitious strength, probably by abstraction of water. A sixty per cent. acid requires dilution before it can be used for etching glass; too strong an acid etches glass roughly. An acid of 70 per cent., and containing 5.76 per cent. of H_2SO_4 , instantly converted filtering-paper into a jelly at 60° FAHR.; it was too strong for retention in gutta-percha bottles.

A small gutta-percha jug of the annexed form was sometimes employed for Fig. 14. taking the specific gravities of samples of weak acid. The neck of the vessel was less than half an inch internal diameter, and was closed by placing a gutta-percha ball with a handle loosely in it. Any excess of liquid above the ball was absorbed by application of sponge previous to weighing.



Sulphurous acid is frequently present in commercial hydrofluoric acid to such an extent as to be readily detected by the odour; it may be easily found by adding shavings of metallic tin to the acid. Tin was found to be much better than zinc; it produced a cloud of sulphur at once, and evolved sulphuretted hydrogen readily. Bifluoride of tin also evolved sulphuretted hydrogen easily. Sulphuretted hydrogen gas in excess was passed through commercial hydrofluoric acid; some time after the commencement of its passage free sulphur appeared, and then accumulated quickly. No increase of sulphuric acid was found in the liquid after this reaction. If the reaction is correctly represented by the following equation, $2\text{H}_2\text{S} + \text{SO}_2 = 2\text{H}_2\text{O} + 3\text{S}$, then 96 parts by weight of sulphur

separated, equal 64 parts of sulphurous acid present. One gallon of a mixture of different samples of commercial hydrofluoric acid of specific gravity 1.25 yielded by the above treatment $3\frac{1}{2}$ avoirdupoise ounces of dry sulphur = 1.145 per cent. of SO_2 . Another sample yielded sulphur equal to 2.72 per cent. of SO_2 thus. I have not determined the amount of hydrochloric acid in commercial hydrofluoric acid; it is, however, quite small; nor have I ascertained the quantity of arsenic, which is also small.

The total amount of all the free acids present in a sample was roughly determined by adding a known weight of pure precipitated dry carbonate of calcium to it, until the liquid exhibited a neutral reaction to test-paper after expulsion of the liberated carbonic acid by heat. A standard solution of carbonate of sodium is inapplicable for the purpose, because the fluoride of sodium produced has an alkaline reaction.

To find the amount of free sulphuric acid, 100 grains of the acid was carefully evaporated in a platinum dish at a gentle heat until all sulphurous, hydrofluoric, hydrochloric, and hydrofluosilicic acid was expelled; the residue was then exactly neutralized by a standard solution of carbonate of sodium in the usual manner, and the amount of sulphuric acid calculated therefrom. The residuary acid liquid was in some cases diluted with water, filtered, acidified with a little hydrochloric acid, and the total amount of sulphuric acid in it determined by the ordinary gravimetric process with solution of chloride of barium.

To determine the amount of hydrofluosilicic acid, an excess of dilute aqueous ammonia was added to 100 grains of the acid previously diluted in a large platinum dish, and the silica separated from the washed precipitate (which usually contains iron and sometimes lime) in the usual manner and weighed. 30 parts of Si O_2 equal 72 parts of HF , Si F_4 .

The most feasible method of determining the amount of HF in the impure acid consists in neutralizing it with hydrate of potash, evaporating the liquid to a small bulk, adding an excess of precipitated silica, heating the mixture with sulphuric acid, and ascertaining the amount of silica dissolved, and calculating it as fluoride of silicon (see pages 176, 177, & 178). Numerous attempts were made to determine the amount of HF by diluting the acid, digesting it with pure precipitated silica, and calculating from the amount of silica dissolved the amount of HF present; but the results were not even approximately accurate, they were calculated too highly, apparently owing to the formation of a variable mixture of Si F_2 and HF , Si F_2 .

The sulphate-of-calcium residue from the manufacture of hydrofluoric acid is liable to contain minute amounts of potassium, sodium, lithium, thallium, and copper; also iron freely (derived from the action of the ingredients upon the iron retort), and some free sulphuric acid. Upwards of fifty-six pounds weight of the residue was digested and washed with eight or ten gallons of distilled water, the clear liquid evaporated to small bulk in a leaden pan, and the greater portion of the free sulphuric acid expelled by heating in a platinum dish, the residue diluted, filtered, and precipitated by sulphuretted hydrogen (the yellowish-brown precipitate contained copper and thallium); most of the iron was then separated as sulphate by crystallization, and nearly all the remainder pre-

precipitated by ammonia; the filtrate was evaporated and ignited in a platinum dish to expel the sulphate of ammonium; the ignited residue was dissolved in water and precipitated by carbonate of ammonium; the precipitate contained thallium distinctly, and the filtrate contained thallium, sodium, lithium, and potassium salts.

The following is the process employed by me for purifying ordinary hydrofluoric acid. Pass sulphuretted hydrogen through it until it contains the gas in excess; this separates the sulphurous acid (and also the arsenic if the acid is not too strong). Stir thoroughly. Find the amounts of free sulphuric and hydrofluosilicic acids present by the means already described (see page 195), and add a little more than sufficient carbonate of potassium to neutralize them, *i. e.* 138 parts of anhydrous carbonate to 98 parts of H_2SO_4 , or 60 parts of SiO_2 *. Subside until quite clear and cold, and decant the clear liquid. The effervescence, stirring, and exposure to the air expels nearly all the excess of sulphuretted hydrogen; careful addition of carbonate, oxide (or fluoride) of silver will remove the remainder. Distil the clear liquid in a leaden retort immersed in a bath of linseed-oil at a temperature varying from about 320°FAHR. to about 460°FAHR. , using a LIEBIG'S condenser, containing a platinum tube to condense the vapour†. The acid requires to be redistilled once to render it quite pure. If the liquid product contains more than about 40 per cent. of anhydrous acid it will probably contain arsenic; this may be precipitated by diluting the liquid and passing a prolonged current of sulphuretted hydrogen gas through it. Avoid contact of the pure acid with leaden vessels. (Or the following modification of the process might probably be employed:—Find amounts of sulphuric and hydrofluosilicic acids present; add more than sufficient carbonate or sulphide of potassium to neutralize them. Subside, decant the liquid, and dilute it with water until it contains not more than about 40 per cent. of anhydrous acid. Pass an excess of sulphuretted hydrogen through it, filter, and distil.) I have made several gallons of the pure acid on various occasions by the first of these processes.

Hot junctions in the distillatory apparatus are best made gas-tight by vulcanized india-rubber washers, or by binding them round with ribbon of the thinnest and best quality of vulcanized rubber secured by tarred string. Strong hydrofluoric acid containing traces of lead yielded no precipitate on addition of sulphuretted hydrogen water; nor did I succeed in removing the lead by electrolysis; it was partly precipitated by hydrochloric acid and by sulphuric acid.

The acid prepared by the foregoing process was very pure; it yielded only a trace of fixed matter (probably derived from the gutta-percha bottle, see pages 193 & 194) on evaporation to dryness in a bright platinum dish; it evolved no sulphuretted hydrogen or sulphur by addition of zinc or tin; it gave no precipitate or coloration by addition of the following substances:—excess of aqueous ammonia or of pure anhydrous carbonate

* One gallon of mixed samples of ordinary hydrofluoric acid required $22\frac{1}{2}$ ounces of carbonate of potassium of 92 per cent. to neutralize its sulphuric and hydrofluosilicic acids.

† The tube employed by me was 6 feet long and $\frac{1}{2}$ inch diameter, and was kindly lent to me by Messrs. MATTHEY and Co.

of potassium, strong solution of fluoride of potassium, excess of sulphuretted hydrogen gas (either before or after neutralization of the acid by ammonia), dilute hydrochloric acid, solution of nitrate of silver, nor by adding a single drop of solution of nitrate of barium acidulated with nitric acid; it was therefore free from all impurities at all likely to be present. Additional tests were employed which need not be enumerated. This aqueous acid was employed in making the various fluorides described in this paper. I have found a plentiful supply of the pure aqueous acid of considerable service for removing (by digestion and evaporation) the silica in minerals, especially in searching for minute ingredients in those containing much silica.

The amount of anhydrous hydrofluoric acid contained in the pure aqueous acid of various degrees of strength was ascertained both by the silica-process (see pages 176, 177, 178, and 195) and also by the lime-process (see page 178).

Aqueous hydrofluoric acid of a high percentage was also on two occasions prepared by heating dry fluoride of chromium in a suitable platinum apparatus, and condensing the vapour by immersing the condensing-tube in a mixture of snow and salt. The chromium salt was prepared by precipitating a solution of chrome-alum by aqueous ammonia, and boiling with excess of the ammonia, washing the precipitate with boiling water, dissolving it whilst still wet in pure dilute hydrofluoric acid, and evaporating the solution to perfect dryness in a platinum dish. The residue was a pale green earthy powder, non-deliquescent, and very slowly soluble in water or dilute hydrofluoric acid; it lost upwards of 40 per cent. in weight of acid vapour when heated to redness in platinum vessels, without contact of the substance with the products of combustion from the gas-burner.

The following apparatus was employed:—A (fig. 15) is a retort-tube 7 inches (=17·8 centimetres) long and $\frac{5}{8}$ of an inch (=1·6 centim.) diameter; B is an angle-tube, and C is a curved tube about 5 inches (=12·8 centims.) high and $\frac{1}{2}$ an inch (=1·2 centim.) diameter. Each tube was formed of platinum without the use of solder. The tubes fitted tightly upon each other, and the junctions were made gas-tight by means of the melted mixture of sulphur and lampblack.

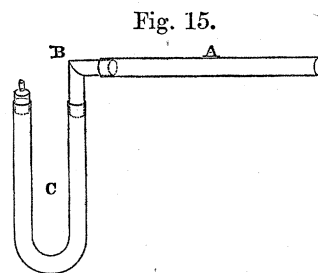

Fig. 15.

The outer end of the tube C was closed by a paraffin stopper containing a small platinum escape-tube.

50 grains weight of the dry chromium salt was placed in the tube A at its closed end, and the whole tube heated somewhat above the boiling-point of water; no perceptible loss of weight occurred: the tubes were then joined together, the curved tube C immersed in snow, a wet rag laid upon A near its junction with B, and heat very *gradually* applied to the outer end of A during about twenty minutes until about 3 inches in length of the tube was red-hot; the tube A was then taken off, the adhering cement removed, and the tube weighed; the loss of weight was 22·10 grains=44·20 per cent. (this number, however, is a little too high because traces of the solid substance were carried forward mechanically into the angle-tube); only a trace of vapour escaped con-

densation. Various other fluorides besides that of chromium evolve much hydrofluoric acid when heated.

A very weak acid became concentrated to a large extent by desiccation over strong sulphuric acid in a closed leaden chamber at 60° FAHR.; but as the concentration proceeded the acid itself began to volatilize along with the water, until finally the vessel became empty. The sulphuric acid acquired an acid odour as if it had absorbed some of the hydrofluoric acid.

Pure aqueous hydrofluoric acid of about 40 per cent. in strength did not show any signs of solidifying by prolonged immersion in a freezing-mixture at -24° FAHR.; nor did a mixture of two measures of that acid with one of water freeze at that temperature; but with $1\frac{1}{2}$ measure it froze imperfectly, and with 2 measures became nearly solid: no vapour of hydrofluoric acid appeared to escape during the solidification. It is evident from these experiments that a comparatively small quantity of hydrofluoric acid lowers the freezing-point of water very considerably.

The chemico-electric series of metals &c. in pure dilute hydrofluoric acid at 60° FAHR. containing about 10 per cent. of anhydrous acid was determined. The order obtained was as follows, the most positive substance being named first:—Aluminium, zinc, magnesium, thallium, cadmium, tin, lead, silicon, iron, nickel, cobalt, antimony, bismuth, copper, silver, gold, gas-carbon, and platinum. The aluminium evolved gas rapidly. The following series was obtained with pure hydrofluoric acid containing about 30 per cent. of anhydrous acid:—Zinc, magnesium, aluminium, thallium, indium, cadmium, tin, lead, silicon, iron, nickel, cobalt, antimony, bismuth, mercury, silver, copper, arsenic, osmium, ruthenium, gas-carbon, platinum, fused rhodium, palladium, tellurium, fused osmi-iridium, gold, iridium*. Magnesium was remarkably unacted upon by aqueous hydrofluoric acid.

The chemico-electric position of aqueous hydrofluoric acid to that of other acids was ascertained as follows:—A diaphragm of parchment-paper was fixed upon the end of a short piece of platinum tube, about $\frac{1}{2}$ an inch wide and 1 inch long, by means of a ring of gutta percha sealed at its edge with paraffin. The acid to be compared with it was put into this porous vessel, and the vessel immersed in aqueous hydrofluoric acid contained in an outer cup of platinum. With the outer vessel connected with one pole of a galvanometer and a sheet of platinum immersed in the inner liquid and connected with the other pole, and with acid of $28\frac{1}{2}$ per cent. in the outer vessel, the following electrical order of acids was found, the first-named being the most electro-positive:—Strong aqueous phosphoric acid, aqueous hydrofluoric acid, concentrated sulphuric acid, strong hydrochloric acid, strong nitric acid. The current in each case passed from the positive acid through the diaphragm to the other acid.

According to FARADAY (GMELIN'S Handbook, vol. i. p. 455) hydrated hydrofluoric acid is not decomposed by electrolysis, only the water in it is decomposed. I electrolyzed

* I am indebted to the kindness of Messrs. MATTHEY and Co. for the specimens of osmium, ruthenium, rhodium, and iridium.

dilute pure hydrofluoric acid of about 10 per cent. by means of six SMEE'S cells, a platinum-foil anode, and a platinum crucible cathode. Gas was liberated freely from each electrode, and a very strong odour like that of ozone was evolved. No corrosion of either electrode took place during twelve hours' action. I also electrolyzed the same acid by six GROVE'S cells and platinum electrodes, the anode being enclosed air-tight within a gutta-percha funnel inverted in the acid, an exit-tube with a tap being in the side of the neck of the funnel for regulating the escape of the gas. Free conduction occurred. Plenty of gas was evolved. The gas from the anode smelt powerfully of ozone, and inflamed a red-hot charcoal splint vividly. Paper wet with spirits of turpentine was not blackened in the strongly issuing stream of gas, nor was bright silver affected in it. No corrosive action occurred upon the anode. I prepared some pure hydrofluoric acid containing about 80 per cent. of anhydrous acid, by taking one part by weight of 40 per cent. pure hydrofluoric acid in a bent tube C (of the apparatus, page 197) immersed in a stream of cold water, and passing through it about two parts by weight of anhydrous hydrofluoric acid vapour, obtained by very gradually fusing and heating to redness eight parts of anhydrous double fluoride of hydrogen and potassium contained in the platinum tube-retort A, to which the bent platinum tube was fixed. The acid thus obtained was electrolyzed by ten SMEE'S cells with platinum electrodes in a narrow and deep platinum cup, the cup being the negative pole. Copious conduction occurred; a powerful odour of ozone was evolved, indicating decomposition of the water and evolution of oxygen gas at the anode; much gas was liberated, and doubtless consisted chiefly of hydrogen. Heat was evolved in the liquid by the conduction-resistance. The anode dissolved, but not very rapidly; in three hours it lost 1.58 grain, and indicated the simultaneous decomposition of the acid with that of the water, the latter being the greatest in amount. The smell of ozone disappeared if the battery was weak, and reappeared on first contact. In a further eleven hours the anode lost 5.05 grains, and was covered with a blackish crust; this crust was partly soluble in water to a brownish solution. In a further twenty-two hours the loss had increased from 5.05 to 15.00 grains without any signs of an electro-deposit of platinum upon the platinum cathode tube. The total loss of the anode was $1.58 + 15.00$ grains = 16.58 grains. Found 15.5 grains of black-brown powder which showed some metal by pressure between surfaces of agate. I also electrolyzed pure 30 per cent. hydrofluoric acid by platinum electrodes and ten SMEE'S cells, the liquid being mixed with other pure acids. With equal volumes of hydrofluoric acid and concentrated nitric acid, gas was evolved freely from the anode; it had no odour of ozone, and was probably ordinary oxygen. No gas was visible at the cathode; the liberated hydrogen was doubtless absorbed by the nitric acid. Only a trace of platinum was dissolved during sixteen hours' action; the liquid was then pale yellow, but became dark green, evolved abundance of red-brown fumes, and became hot on addition of water. With equal volumes of aqueous hydrofluoric and strong hydrochloric acids, much chlorine was evolved from the anode and hydrogen from the cathode; this agrees with the usual results, that chlorides (as well as oxides) are decomposed before fluorides, and hydro-

chloric acid before water in electrolysis. Only a trace of chloride of platinum was formed at the anode in four hours, and the anode was not visibly corroded. With equal volumes of aqueous hydrofluoric and strong sulphuric acids much gas and a strong odour of ozone was evolved from the anode; hydrogen also from the cathode. The anode corroded very slowly, without being covered with an insoluble film, and the liquid became cloudy with suspended particles, which were light brown at first, then brown, and after many hours' action nearly black. The fumes from this mixture rapidly blackened gutta percha. With hydrofluoric acid containing much selenious acid dissolved in it, gas was evolved from both electrodes, and a liberal deposit of red selenium formed at the cathode. No odour of ozone occurred until a large quantity of red and black selenium (probably nearly all) was deposited upon the sides and bottom of the platinum cup, then ozone occurred strongly. The anode was not visibly corroded in twenty-eight hours' active electrolysis. The solution was filtered and evaporated to a small bulk; it then fumed densely: the odour was like that of hydrofluoric acid, and when cold the liquid was odourless and of a somewhat oily consistence. The final liquid evolved a little heat on adding water to it. I found traces of platinum in the deposited selenium. With aqueous hydrofluoric acid, to which some phosphoric anhydride had been freely added, ozone was evolved from the anode, and hydrogen from the cathode; the anode was slowly corroded, and a small quantity of black precipitate formed; the liquid remained nearly colourless.